

DUPLEX WATER SOFTENER SYSTEM

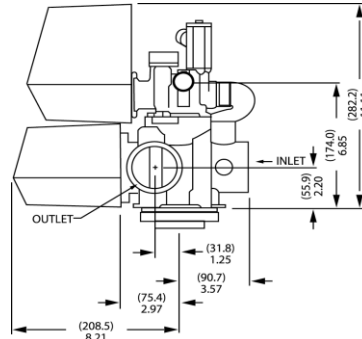
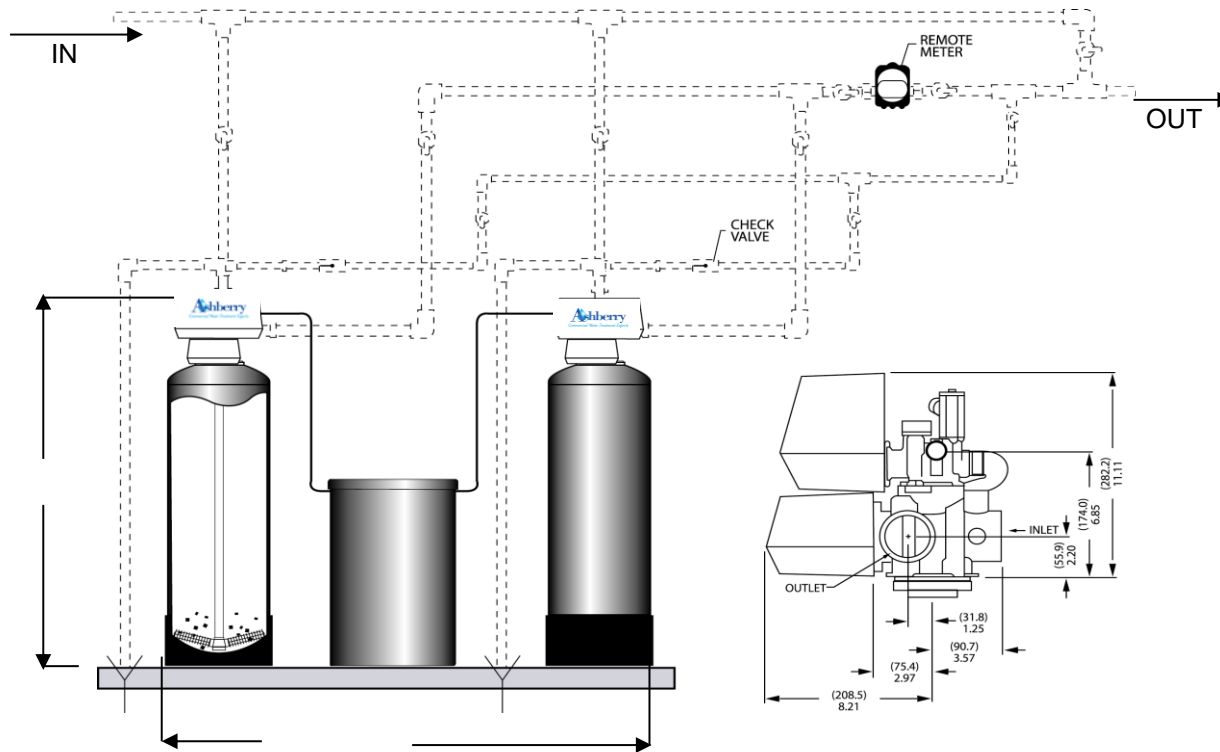
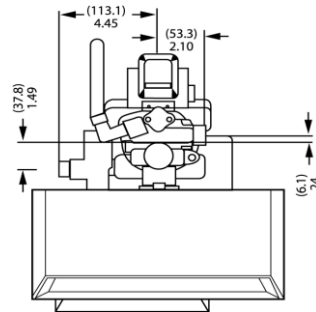

Water Softener Specification

Model #	ASH-1200-3-ALT
Capacity:	*1,200,000 Grains ea.
Flow Rate:	205 GPM
Peak Flow:	275 GPM
BW Rate:	55 GPM
Tank Size:	48" X 72" Fiberglass
Brine Tank:	50" DIA. X 60" Poly
Media Vol.:	40.0 FT³ ea.
Valve:	3900
Pipe Size:	
Inlet:	3" NPT
Outlet:	3" NPT
Drain:	2" NPT
Alternating:	Single meter
Progressive:	Meter per tank
Weight:	
Shipping:	

Note:

Supply sufficient pipe support to insure that no pipe weight is supported by the softener control.

All Dashed pipe, valves and fittings provided by others.

Make all plumbing connections in accordance with all state and local plumbing codes.

Install sample valve on softener outlet for ease of sampling water hardness.

*Maximum capacity per regeneration @ 15lbs salt dose

